

AVIATOR

Professional dual-arm Camera Stabilizer Instruction Manual

Please read the instruction manual thoroughly before operating your aviator stabilizer for the first time to avoid injuring yourself or damaging the unit.

The robust construction of the aviator makes it an excellent long-term investment, but its precision design also means that you must exercise care in the storage, transport, and operation of the unit to ensure optimal long-term performance.

You should also review the accompanying instructional DVD before attempting to shoot usable footage with the aviator. The standard aviator comes equipped with 3 subsystems:



and the following: 7" 16:9 monitor, padded rolling case, DVD, hex wrench, BNC-RCA video cable, battery & charger, handle extension & docking post (for mounting and balancing sled on a C-stand or light stand).

VariZoom
11700 Bell Avenue
Austin, TX 78759
888-826-3399
www.varizoom.com

Page 2

Aviators with Optional Battery Mounts

If you ordered your aviator with one of the optional battery mounts (AB, NP, V-lock), your kit will not include the battery and charger.

***Subsystems
The Vest***

The purpose of the vest is to comfortably distribute the weight of the camera and stabilizing system on your body. To achieve optimal results, you should adjust the vest so that it fits snugly.

- Adjust the vertical fit by adjusting the straps, pulling the chrome release pin and sliding the chest plate up or down until you find the right position.

- Adjust the tightness of the vest around your waist using the Velcro strap, drawing it around evenly on both sides of the lower vest pad.

- Adjust the tightness around your torso by positioning the Velcro straps across the back of the vest and securing the buckles to the chest plate. Make the vest as tight as possible to maximize operational quality and comfort. Once you've adjusted the vest, remove it for easy re-suiting by unclipping the buckles and strap on one side only.



Page 11

Low Mode Assembly

The Low Mode kit consists of the camera cage, the sled-to-arm tie rod, and a few screws.

Start by attaching the dovetail plate (upside-down) to the top of the camera

cage using the supplied screws (the top of the cage has threaded holes).

Then turn the sled upside-down and slide the dovetail plate into the stage. Mount the camera inside the cage using the supplied screw. Connect the sled to the arm using

the tie rod; the gimbal handle should fit into the round hole on the oval shaped end of the tie rod and the squared end should slide over the post on the spring arm.

The stage knobs and multiple cage holes allow for horizontal balance adjustment, and you can adjust the vertical balance using the same adjustments as in normal upright mode.

Camera cage may differ slightly from those pictured



Page 4

insert the charged battery into its housing (LEDs facing out) and plug in the connector cable, then tighten the screws. To prepare the camera for attachment to the sled you should first find the center of gravity (CG) of the camera. The CG is the point at which the camera will balance best, and it can be determined by using a rounded object such as a pencil. Set the camera lengthwise on top of the pencil so that it is balanced to find the lateral center (side-to-side), and then set it on top of the pencil in a perpendicular orientation to find the longitudinal center (front-to-back). The spot where the lateral and longitudinal centers intersect is the CG – you may want to mark the CG with a grease pencil or non-permanent marker.

Once the CG is determined, you must mount the camera to the dovetail (mounting plate) using a hole that will put the CG closest to the center of the mounting platform. Look at the bottom of the dovetail - on one side you will see a metal rack of teeth and on the other side a pair of sloped end stops. When you attach the dovetail to the camera, you want the rack to be on the same side as the viewfinder (or lcd display) so that it will line up with the brass gear in the dovetail channel of the stage.

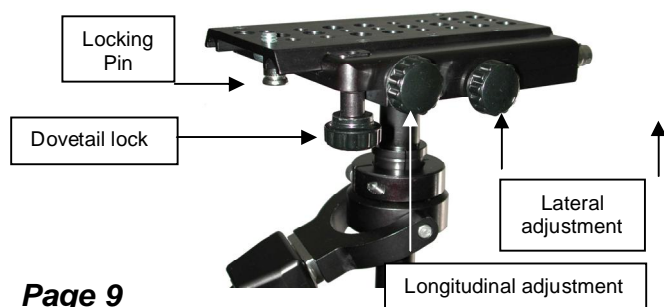

Page 9

If the sled is not already mounted to the arm, do so. Now you need to Set the “float point”, which is the ideal point of arm spring tension. At the end of each arm section you will

find a thumbscrew for adjusting the spring tension. Clockwise turning increases tension while counter-clockwise turning decreases tension.

You will want to play with the independent adjustments of each arm section until you get the right cumulative force. There should be some degree of balance between the two sections, but the lower arm section bears more weight, so the amount of adjustment may be different. Set the adjusters until both arm sections are near or above a horizontal level and the arm is compliant but not ‘mushy’.

The float point is not necessarily an exact setting, and you may find that what works for you is slightly different than another person’s preferred float point. The important thing is the end result: you have a sled that rises and falls with slight force and absorbs most of the shock imparted by walking.

Now you should be able to turn on the monitor and begin practicing, assuming the battery is charged. You may need to adjust the balance slightly after positioning the monitor.

Page 10 **OPERATION**

For instructions on operation, watch the DVD. Generally speaking, you have to keep in mind that the stabilizer will not work like a magic wand and instantly transform your shots into brilliant footage. Operator skill is critical, and it takes many hours of practice to master this device, but the

reward for all the practice will be substantial. Here are a few simple quick-start guidelines:

- Hold the system by the gimbal handle to control the orientation and elevation of the sled.
- With the other hand, lightly grasp the center post of the sled just below the gimbal, holding it close to the gimbal for optimal control.
- Delicately grasp the center post with your fingertips, like a flute – do not grab it like a handlebar.
- Practice good posture and hold the sled close to your body.
- Fine-tuning of the balance adjustments may be necessary a few times during operation.
- The way you walk will affect the quality of stabilization, so you need to develop a light-footed rhythmic pattern.
- Practice for at least 20 hours before attempting to acquire usable footage.

The DVD contains detailed, clear instructions and tips on operation, and if you have any general questions, visit the website – www.varizoom.com. If you've watched the video and practiced and still have technical questions, call 310-545-0466.

Page 3 **The Sled**

The Sled is the subsystem that holds the camera, viewing monitor, and battery. The Sled mounts to the arm, and in tandem they create a stabilizing effect.

The Sled can be adjusted at various points to change its weight distribution, which in turn enables you to accommodate cameras of different sizes, shapes and weights. The basic principles of sled adjustment are that you want the section of the sled below the pivot point

(Gimbal) to be effectively heavier than the upper section, and you want the camera's mass to be centered on the rotating axis. It is easier to balance the sled with the aid of a c-stand, but it can also be done while it is mounted to the arm.

The Stage enables you to adjust the horizontal balance of the system and houses the video and power connectors.

The Post and Gimbal provide smooth pan and tilt action, a mounting socket for the spring arm, and a grip handle. This section also features one of several vertical balance adjustment points.

The Lower Sled holds the LCD monitor and battery. To fix the monitor to the swivel mount, line up the flat edges of the screw with the slot so it will slide on, tighten the knob, and plug in the video and power cables.



Page 6

P1 - Weight Plate Attachment - If your fully loaded camera weighs less than 10 lbs, you will have to attach the supplied weight plate.

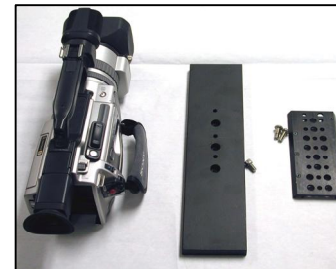

- Start by mounting the weight plate to the camera (above) –

The weight plate comes with several screws, and you will use the shorter hex socket head screw to attach the weight plate to the camera. This screw will go into one of the counter-bored holes. You should try to position the weight plate so that the camera's CG lines up with the centermost hole of the weight plate. Use the supplied 3/16" hex wrench to tighten the screw.

- Next, attach the dovetail to the weight plate using the two slot-head screws (see pictures below). Slide the assembly into the stage and you're ready to continue.



Page 7

You are now ready to learn the balancing procedure. Pick up the sled/camera assembly and place the gimbal handle onto the steel post at the top of the vest-mounted arm (or onto the c-stand adapter post). The post should slide up into the socket of the gimbal handle, securing the sled in place. Now you can check the vertical balance of the sled. Make sure the dovetail is locked. If balancing the sled while on the arm, Grasp the gimbal handle as a control point and hold the arm in place. Using your free hand, turn the sled 90 degrees so that it is horizontally oriented, and let it drop back to the vertical position. **Keep** your free hand close to the center post of the sled in order to maintain control of the swinging action.

Ideal vertical balance is reflected by a “drop time” of 2-3 seconds, meaning it should take 2-3 seconds for the sled to swing down 90 degrees to the vertical plane (it will swing past that point, but count only until it reaches the vertical plane). If the system is top heavy (more than 3 sec), adjust the balance by repositioning the gimbal assembly upward, and if it is bottom heavy (less than 2 sec), move it downward. When you loosen the gimbal clamp with your 3/16" hex key, you should support the weight of the sled by grasping the center post firmly. **Make sure you leave a gap between the gimbal clamp and the bearing below it. If the gimbal clamp rides on top of the bearing, it will cause drag on the pan action.** You can further adjust the vertical balance by extending the lower sled downward, which will make the system more bottom-heavy.

Page 8

To extend the lower sled, loosen the hex screw on the knurled clamp (using the 3/16" hex key) while supporting it from below. *Be careful not to overextend the lower sled, as there are wires inside the center post (there is a safety catch, but don't test it).* When you find the right position, tighten the knurled clamp just enough to fix the lower sled in place (don't overtighten). Test for 2-3 sec Drop time and adjust, if necessary.

Special Note: Cameras near the top of the aviator's weight capacity may need additional counterweight to achieve proper vertical balance. If you cannot achieve vertical balance by adjusting the gimbal position upward and extending the lower sled and battery housing fully, you may need to attach the included lower sled side weights – see pictures below.



Now you can adjust the horizontal balance, which is accomplished by adjusting the longitudinal and lateral positions of the camera on the stage. Loosen the dovetail lock and adjust the knob at the front of the stage until the camera is level. If the sled leans to one side, you can adjust the stage laterally by using the second knob. Both knobs adjust in very fine increments, so you will find it is best to turn them slowly until you hit the “sweet spot” (where the camera stays totally level). Finish by tightening the dovetail lock.

Page 5

Once it is securely fastened, slide the mounting plate into the dovetail channel of the stage while making sure the rack is on the same side as the brass gear. You may need to push up on the dovetail lock to fully install the plate. Position the dovetail so that the camera is fairly centered. When properly installed, the locking release pin should prevent the plate from sliding out, but you should go ahead and secure your camera by tightening the dovetail lock.

Plug your video cable from the camera to the video output on the back of the stage. Set the sled/camera assembly aside, as final setup must be done with the arm and vest mounted on your body or using a C-stand. Use the supplied docking post to mount the sled to a C-stand. Exercise caution to make sure the stand will not tip over (use sand bags if needed).

The Arm

The arm is the link between your body and the sled. The arm provides vertical support and allows the camera and sled to float. The Aviator arm is a double-articulated, spring-loaded arm designed to handle cameras 5 to 15 pounds. For cameras under 10 pounds, you will have to use the supplied weight plate. Once you determine the exact weight of your fully loaded camera, you can decide if you need to use the weight plate.

If your fully loaded camera is between 10 and 15 pounds, you can skip section **P1** on page 6.